

# YX3 225 M-4 IE2

## Abmessungen Drehstrom-Asynchronmotor / dimensions three phase asynchron motor IM B35 (mm)

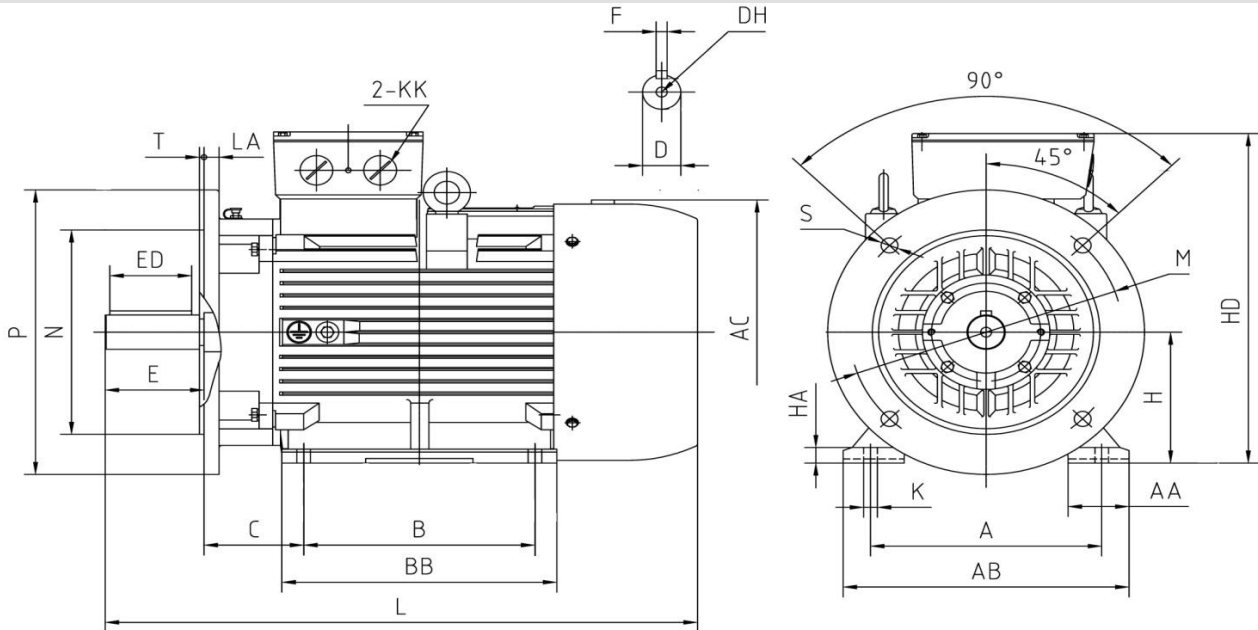

### Abmessungen / dimension

A	AA	AB	AC	B	BB	C	E	ED	H	HD	HA	L	K	D	DH	KK
356	80	436	Ø465	311	380	149	140	110	225	560	28	850	18,5	Ø60	M20x42	M50x1,5
P	M	N	T	LA	S	F										
Ø450	Ø400	Ø350	5	20	8xØ18,5	18										

### Technische Daten / technical dates

Typ / type	<b>YX3 225 M-4 IE2</b>	Nennmoment / rated torque	(Nm)	290,1
Leistung / power	(kW) 45,0	Anlaufstrom-Nennstrom / starting current-rated current	(Ia/I <sub>n</sub> )	6,7
Betriebsart / duty	S1	Anzugsmoment-Nennmoment / starting torque-rated torque	(M <sub>a</sub> /M <sub>n</sub> )	2,4
Nennzahl/ speed	(min <sup>-1</sup> ) 1480	Kippmoment-Nennmoment / Pull-out torque	(M <sub>k</sub> /M <sub>n</sub> )	2,7
Nennstrom / rated current 400 V	(A) 78,3	Massenträgheitsmoment / moment of inertia	(kgm <sup>2</sup> )	0,4878
Spannung / voltage (50 Hz)	(V) 380-420/660-720(Δ/Y)	Umgeb.-temp./ ambient temperature		40°C
Frequenz / frequency	(Hz) 50	Lager / bearing	(DE)	6313
Wirkungsgrad / efficiency	(%) 93,3		(NDE)	6313
Leistungsfaktor / power factor	(cos φ) 0,89	Schallpegel / noise level	(dB (A))	76
Schutzart / protection	IP55	Gewicht / weight	(kg)	355
Isolationsklasse / insulation class	F			

### Schaltplan / connection diagram

