

# YX3 160 L-2 IE2

## Abmessungen Drehstrom-Asynchronmotor / dimensions three phase asynchron motor IM B5 (mm)

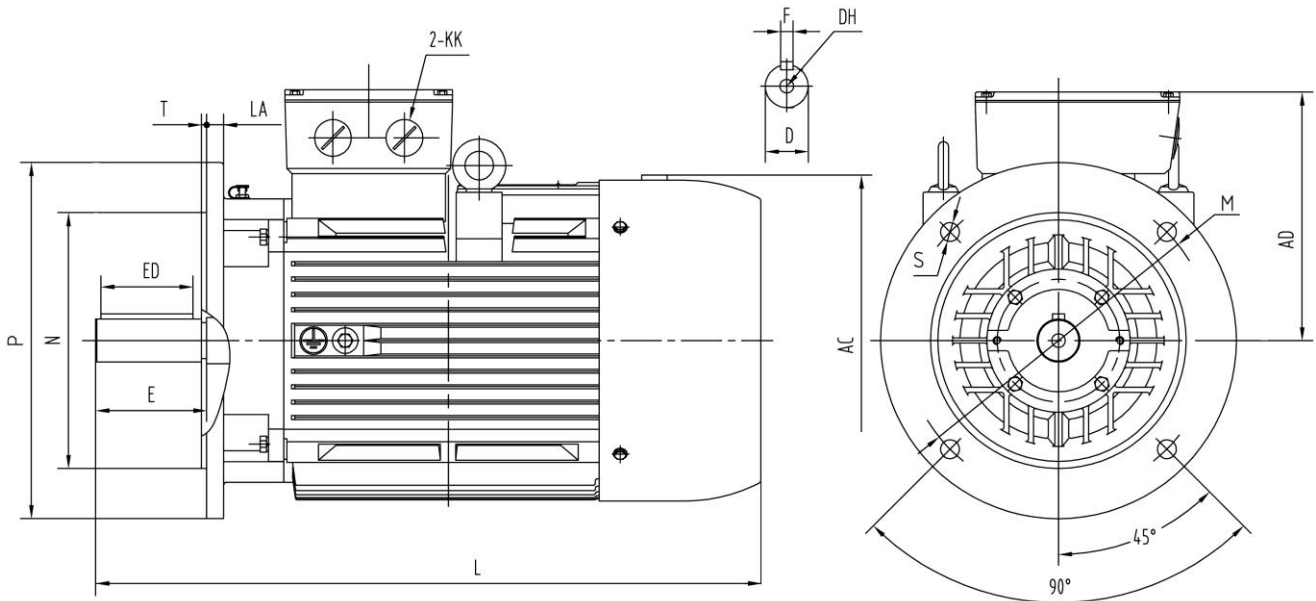

### Abmessungen / dimension

P	M	N	AC	AD	LA	T	E	ED	S	L	D	F	DH	KK
Ø350	Ø300	Ø250	Ø330	250	15	5	110	90	4xØ18,5	655	Ø42	12	M16x36	M40x1,5

### Technische Daten / technical dates

Typ / type	<b>YX3 160 L-2 IE2</b>		Nennmoment / rated torque	(Nm)	60,2
Leistung / power	(kW)	18,5	Anlaufstrom-Nennstrom / starting current-rated current	(I <sub>a</sub> /I <sub>n</sub> )	6,2
Betriebsart / duty		S1	Anzugsmoment-Nennmoment starting torque-rated torque	(M <sub>a</sub> /M <sub>n</sub> )	2,2
Nennzahl/ speed	(min <sup>-1</sup> )	2930	Kippmoment-Nennmoment Pull-out torque	(M <sub>k</sub> /M <sub>n</sub> )	2,8
Nennstrom / rated current 400 V	(A)	31,1	Massenträgheitsmoment / moment of inertia	(kgm <sup>2</sup> )	0,0567
Spannung / voltage (50 Hz)	(V)	380-420/660-720(Δ/Y)	Umgeb.-temp./ ambient temperature		40°C
Frequenz / frequency	(Hz)	50	Lager / bearing	(DE)	6309
Wirkungsgrad / efficiency	(%)	91,2		(NDE)	6309
Leistungsfaktor / power factor	(cos φ)	0,94	Schallpegel / noise level	(dB (A))	75
Schutzart / protection		IP55	Gewicht / weight	(kg)	163
Isolationsklasse / insulation class		F			

### Schaltplan / connection diagram

