

YX3 315 M-2 IE2

Abmessungen Drehstrom-Asynchronmotor / dimensions three phase asynchron motor IM B5 (mm)

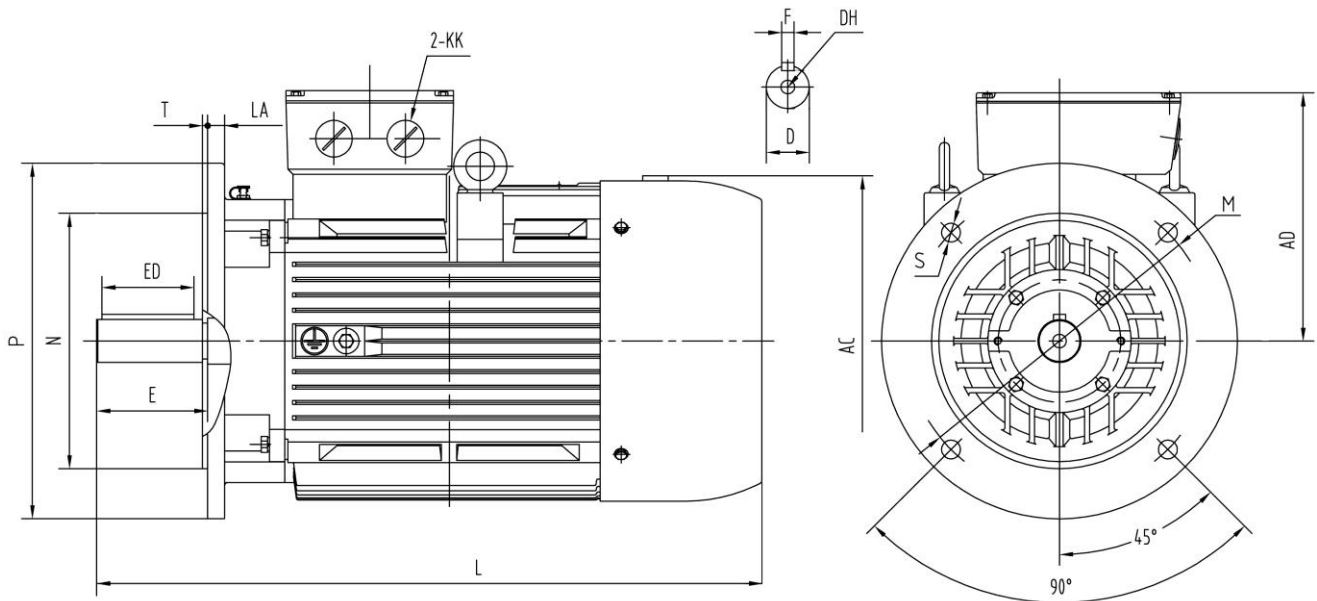

Abmessungen / dimension

P	M	N	AC	AD	LA	T	E	ED	S	L	D	F	DH	KK
Ø660	Ø600	Ø550	Ø650	555	24	6	140	110	8xØ24	1290	Ø65	18	M20x42	M63x1,5

Technische Daten / technical dates

Typ / type	YX3 315 M-2 IE2		Nennmoment / rated torque	(Nm)	423,3
Leistung / power	(kW)	132,0	Anlaufstrom-Nennstrom / starting current-rated current	(I _a /I _n)	7,5
Betriebsart / duty	S1		Anzugsmoment-Nennmoment starting torque-rated torque	(M _a /M _n)	2,4
Nennzahl/ speed	(min ⁻¹)	2940	Kippmoment-Nennmoment Pull-out torque	(M _k /M _n)	3,6
Nennstrom / rated current 400 V	(A)	217,8	Massenträgheitsmoment / moment of inertia	(kgm ²)	1,5965
Spannung / voltage (50 Hz)	(V) 380-420/660-720(Δ/Y)		Umgeb.-temp./ ambient temperature	40°C	
Frequenz / frequency	(Hz)	50	Lager / bearing	(DE)	6316
Wirkungsgrad / efficiency	(%)	95,3		(NDE)	6316
Leistungsfaktor / power factor	(cos φ)	0,92	Schallpegel / noise level	(dB (A))	86
Schutzart / protection	IP55		Gewicht / weight	(kg)	1067
Isolationsklasse / insulation class	F				

Schaltplan / connection diagram

